

VOLVO PENTA INBOARD DIESEL

D3-110

81 kW (110 hp) crankshaft power acc. to ISO 8665



Power for high onboard comfort

Volvo Penta's new 5-cylinder D3-110 is developed from the latest design in modern diesel technology. The low cruising rpm gives quiet running and low vibrations. The engine is extremely lightweight and compact. All these features contribute to exceptional comfort and world-class diesel performance, combined with low emissions.



World-class performance

The common rail fuel injection system, controlled by EVC, in combination with the large swept volume and Variable Geometry Turbine (VGT), ensures outstanding torque during acceleration, with virtually no sign of smoke. The engine's high torque provides excellent operating characteristics to aid maneuvering, particularly in confined spaces.

Low weight

The engine has an extremely low weight for its power output. This thanks to the all aluminum base engine and a highly efficient marinization.

The engine is fitted with freshwater cooling as standard for long service life.

Compact

The engine is ultra-compact for its large swept volume. With cast-in grey iron cylinder liners, a 2-mass flywheel, integrated freshwater pump, a compact marinization, and a fully symmetric engine, the package simply gets that compact.

Comfort

The rigid aluminum cylinder block and bed plate in wedge structure, and exactly controlled high-pressure fuel injection combined with low cruising rpm gives excellent onboard comfort with low noise and vibration levels.

EVC/MC - Plug and go

EVC Electronic Vessel Control is the latest development in instrumentation for marine engines with mechanical shift and throttle.

With EVC/MC you can tailor the instrumentation to fit the boat, from a single tachometer with an LCD window, where you can read all engine/boat data, to a dashboard full with standard gauges or any combination in between. EVC/MC offers an optional multi-sensor to read speed, depth and surface water temp. The system is built on the latest automotive technology with waterproof connectors, so it's just plug and go.

EVC works closely together with the engine management system offering you constant power output regardless of temperature (5–55°C/41–131°F) and quality of the fuel.

Reverse gear

Volvo Penta's hydraulically shifted reverse gears have been specially developed with a view to increasing the standard of comfort on board in terms of quiet running, greater reliability and enhanced efficiency.

The combination of 8° down angle, large drop center and small dimensions provides for optimized installations.

At Volvo Penta, focus is on developing the complete drive line ensuring perfectly matched engine/transmission packages.

Meeting new emission standards

The common rail injection system in combination with electronics and an advanced combustion system are setting new standards in minimizing noxious emissions and particles. The engine will meet future comprehensive emission requirements to be introduced in Europe in 2006 and in the US in 2007.

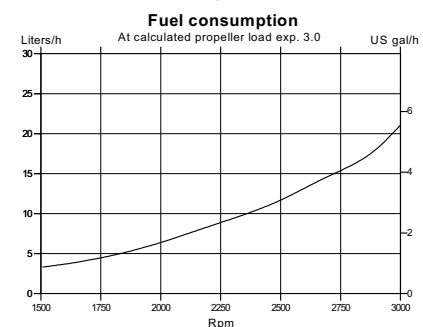
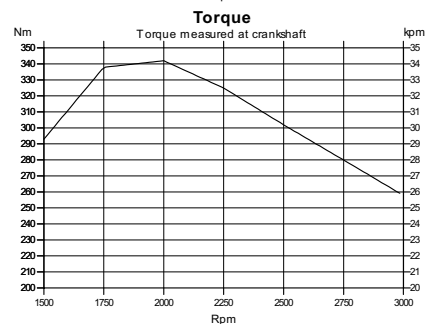
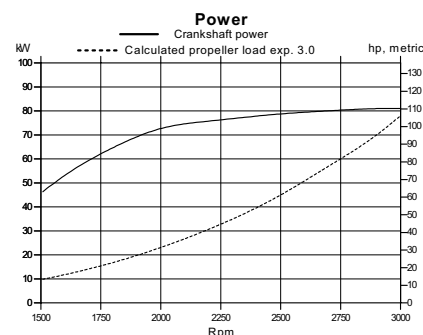

D3-110

Technical description:

Engine block and head

- Cylinder block and cylinder head made of aluminum
- Cylinder block with integrated bed plate
- 4-valve technology with hydraulic lash adjusters
- Double overhead camshafts
- Oil-cooled pistons with two compression rings and one oil scraper ring
- Cast-in grey iron cylinder liners
- Replaceable valve seats
- Six-bearing crankshaft
- Front-end transmission

Engine mounting

- Flexible engine mounting

Lubrication system

- Easily replaceable (insert) full-flow oil filter
- Plate oil cooler

Fuel system

- Common rail fuel injection system
- Control unit for processing the injection
- Fine filter with water separator
- Emergency stop device

Air inlet and exhaust system

- Air filter with replaceable insert
- Closed crankcase ventilation with oil separator of cyclone type
- Exhaust elbow of stainless steel
- Turbocharger with variable geometry

Cooling system

- Thermostatically regulated freshwater cooling
- Tubular heat exchanger with separate large volume expansion tank
- Coolant system prepared for hot water outlet
- Easily accessible impeller pump

Electrical system

- 12V one-pole electrical system
- 140A alternator, and integrated temperature compensated charging regulator

Instruments/control

- Mechanical shift and throttle
- Basic instrumentation including key switch and interlocked alarm
- Plug-in connections

Reverse gear

HS25A Hydraulic – drop center with 8° down angled output shaft. Trolling valve kit available.

HS45A Hydraulic – drop center with 8° down angled output shaft. Trolling valve kit available.

Accessories

An extensive range of accessories are available. For detailed information, please see Accessory catalogs.

Contact your local Volvo Penta dealer for further information.

Not all models, standard equipment and accessories are available in all countries. All specifications are subject to change without notice.

The engine illustrated may not be entirely identical to production standard engines.

Technical Data

| | |
|--|---------------------|
| Engine designation | D3-110 I |
| Crankshaft power, kW (hp) | 81 (110) |
| Propeller shaft power, kW (hp) | 78 (106) |
| Engine speed, rpm | 3000 |
| Displacement, l (in ³) | 2.4 (146) |
| Number of cylinders | 5 |
| Bore/stroke, mm (in.) | 81/93.2 (3.19/3.66) |
| Compression ratio | 18 :1 |
| Engine weight bobtail, approx. kg (lb) | 232 (511) |

Duty rating: R5

Technical data according to ISO 8665. Fuel with a lower calorific value of 42,700 kJ/kg and density of 840 g/liter at 15°C (60°F). Merchant fuel may differ from this specification which will influence engine power output and fuel consumption.

The engine will meet future comprehensive emission requirements to be introduced in Europe in 2006 and in the US in 2007.

Dimensions D3-110/HS25A

Not for installation

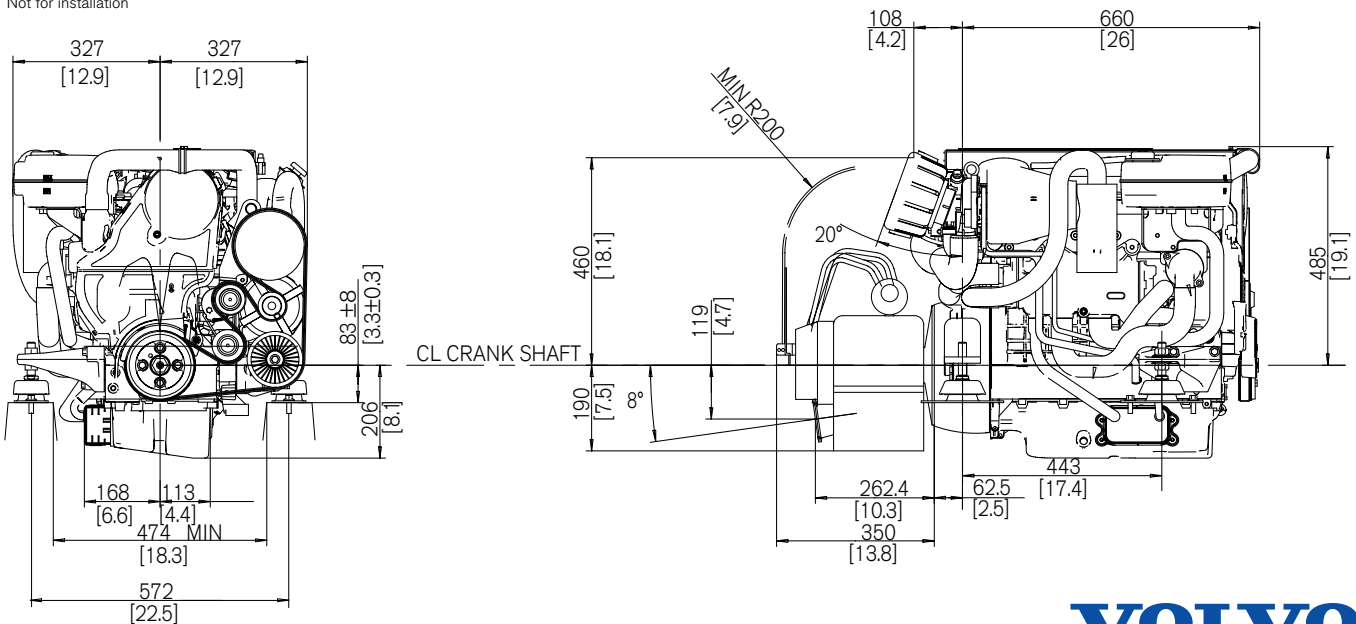

**VOLVO
PENTA**

AB Volvo Penta
SE-405 08 Göteborg, Sweden
www.volvo-penta.com